

Explanation of measuring methods

The radar type 24 speed control system can be positioned in several ways.

Figure 3.1

Correct positioning.
The radar is parallel to the road axis.

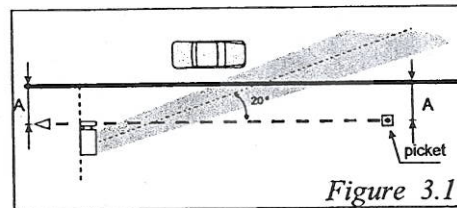

Figure 3.2

Wrong positioning
The radar beam angle is too big (the beam goes too much across the road)

Measurement results.
Measured speed will be lower than it really is. For example, if the angle is too big by

- 1° speed is 0.65 % too low
 - 2° speed is 1.3 % too low
 - 5° speed is 3.5 % too low
- If a cars' speed is 100 km/h, the measured speed will be 96 km/h in case the angle is 5 too big.

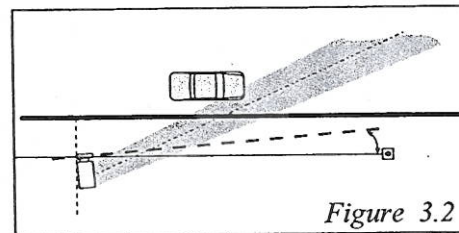

Figure 3.3

Wrong positioning
The radar beam angle is too small (the radar beam is almost parallel to the road).

Measurement results
Measured speed will be higher than it really is. For example, if the angle is too small by:

- 1° speed is 0.64 % too high
- 2° speed is 1.2 % too high
- 5° speed is 2.58 % too high

If a cars' speed is 100 km/h, the measured speed will be 103 km/h in case the angle is 5° too small.

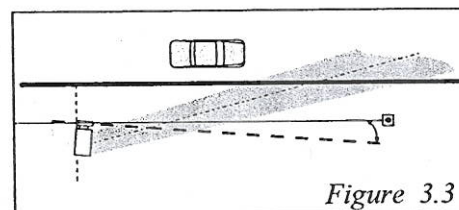

3.1 Receding and approaching traffic

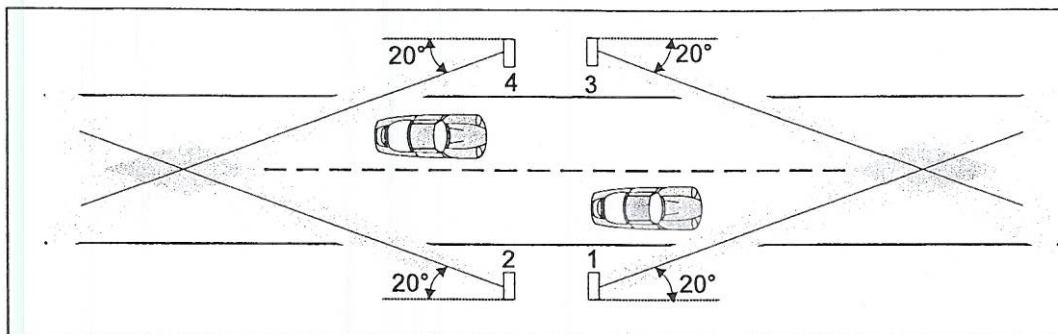

Measurements from positions 1 and 4, of receding as well as approaching traffic, are possible. The radar antenna is installed with the black beam angle indicator on top, aiming at the traffic flow. The camera faces the same direction, and is placed against the right stop.

Measurements from position 2 and 3 of receding and approaching traffic are possible. Now the red beam angle indicator is on top, so that the radar beam is facing the correct direction. The camera will have to be placed against the left stop.

3.2 Approaching traffic

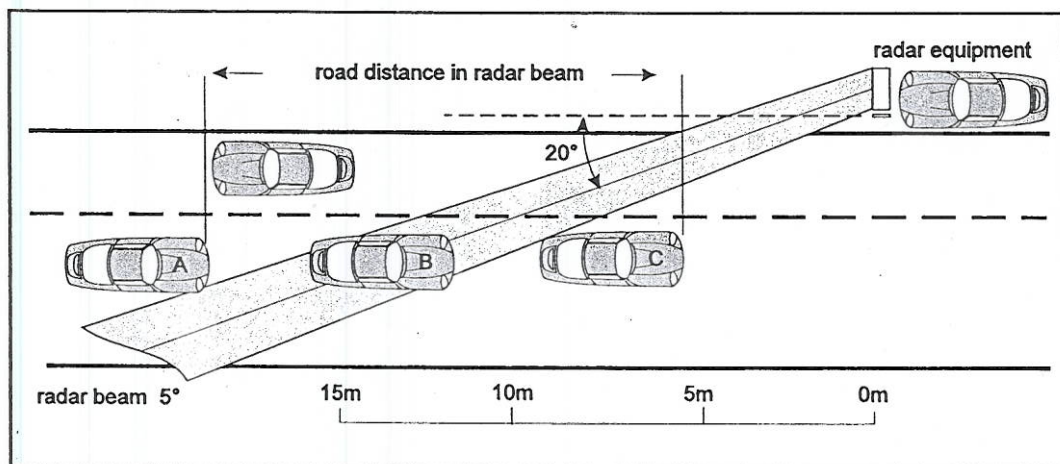

Position of the vehicle

- A drives into the radar beam, start of the measurement
- B is continuously measured. If the vehicle exceeds its' threshold, a photo is taken which is approx. 3.5 m after the vehicle entered the radar beam
- C leaves the radar beam, end of the measurement

3.3 Receding traffic

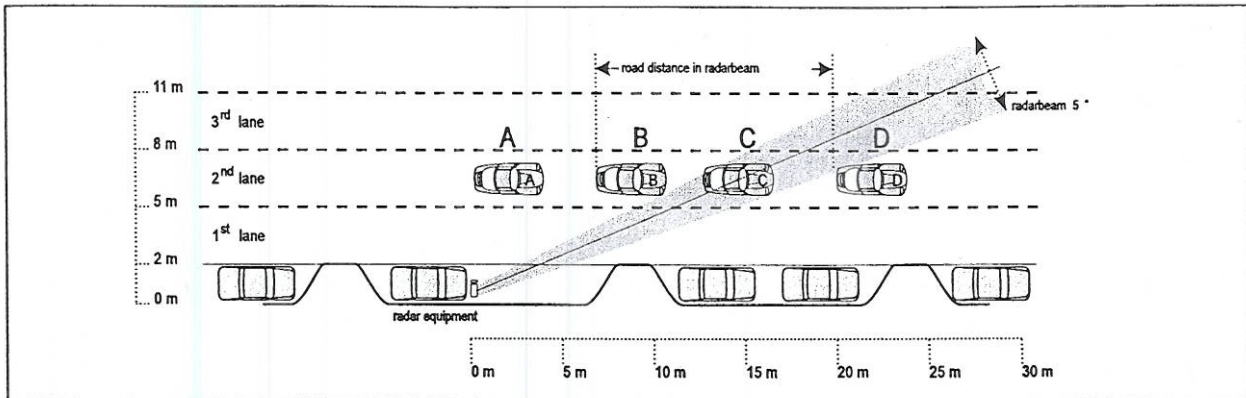

A passes the radar equipment

B drives into the radar beam, start of the measurement

C is continuously measured

D leaves the radar beam, end of the measurement

If the threshold speed was exceeded, a photo would have been taken